



technology that works
Evolution™ EB45R-Sn
 Revolutionising Refrigeration Today

Orford Flower Fridge Range—Sell Fresh Flowers

Full height Internal LED
 “Twin” spread lighting

Dual magnet door
 sealing and plastic
 fascia, thermal break

Ducted air flow system for
 even temperature distribu-
 tion and low velocity air flow
 preventing damage to your
 flowers

EMS controller using
 “smart memory
 functions” automatically
 saving you energy.

Easy access condenser
 Filter

Easy roll lockable
 castors



High Energy Efficiency

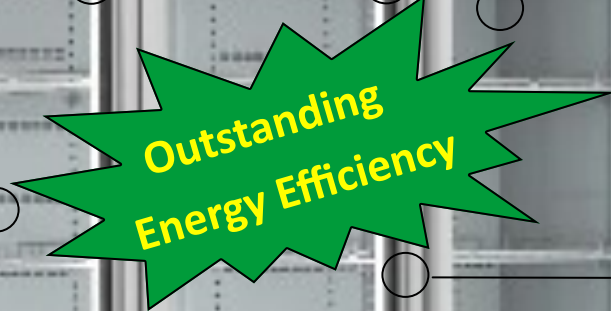

Brilliant LED Sign Panel

Automated and
 Manual
 Lighting control

Self closing
 toughened safety
 glass doors, double
 low E , Argon filled,
 incorporating the
 latest warm edge
 technology

Full Length Easy Grip
 Door Handle

Door sensor
 controlled fan

“Shhhh” whisper
 quiet operation
 utilising patented
 EBM Evap and
 Condenser fan motors
 adding, efficiency
 and unparalleled
 reliability to the new
 Evolution models.

Evolution is an Easy Clip fully removable, universal,
 refrigeration package (one package fits all models).

Proudly Australian Designed

by The Orford Group

www.orford.com.au

www.flowerfridges4u.com.au



IP protected by AUS DSN no 345317



1300 ORFORD (1300 673 673)
 0418 700 006
 sales@orford.com.au
 www.orford.com.au or

PO Box 18120
 Clifford Gardens
 Queensland 4350
 Australia

The Orford Group reserves the right to alter specifications without notice.



Features

World class,

- Design
- Energy Efficiency
- Performance
- Quality
- Reliability

Universal Refrigeration Package

- One package fits the entire **EB** Range
- Cassette Style: Removable without tools
- Minimal training required for

non-qualified personal to replace the package

Energy Management System (EMS)

- Automatically learns you trading times
- Automates your energy savings
- Perishable and non-perishable mode

Lighting Control

- Automated or manual control, you choose
- Independent switching of interior and sign lighting

Condenser Fan Function

- Your choice of reversing or non-reversing function

Condenser Filter

- Easy Access filter: No tools, no covers to remove



High Energy Efficiency

EB45R-Sn	Vertical Display Flower Refrigerator with Illuminated Advertising Sign
Specifications	
Construction	Powder Coated galvanized steel Interior / Exterior White
Capacity	1384 Litres (Gross)
Dimensions	1640W x 762D x 2220H
Weight	265 Kg
Operating Temp	0° - 5° C.
Ambient Temp Range	0° - 40° C.
Power Point	220 - 240v 50Hz. (Standard GPO)
Input Current	3.2 Amps
Thermometer	Digital
Shelves	12 Height Adjustable Heavy Duty PVC Coated
Shelves	3 Fixed Stainless Steel Base Shelves
Shelf Adjustment	12mm Increments
Refrigerated Shelf Area	3.38 m ²
Condensate Disposal	Automatic by energy efficient, No Cost, Hot Gas
Door	3 x Self Closing, Double Glazed Safety Glass, Double Heat reflective Low E, Warm edge
Footings	Heavy Duty Castors, Lockable Front
Interior Light	LED, Automatic and manual control
Refrigerant	R134a
Drier	Solid Core
Insulation	50mm Polyurethane, CFC, HCFC, HFC Free
Cabinet Classes	3M1, 4M1, 5M1
MEPS	Compliant (High Efficiency)
* Energy Consumption	6.03 kWh/24h
Condenser Filter	Easy front access
Illuminated Advertising Sign	200mm High, Top Mounted
Sign Illumination	LED, Automatic and manual control

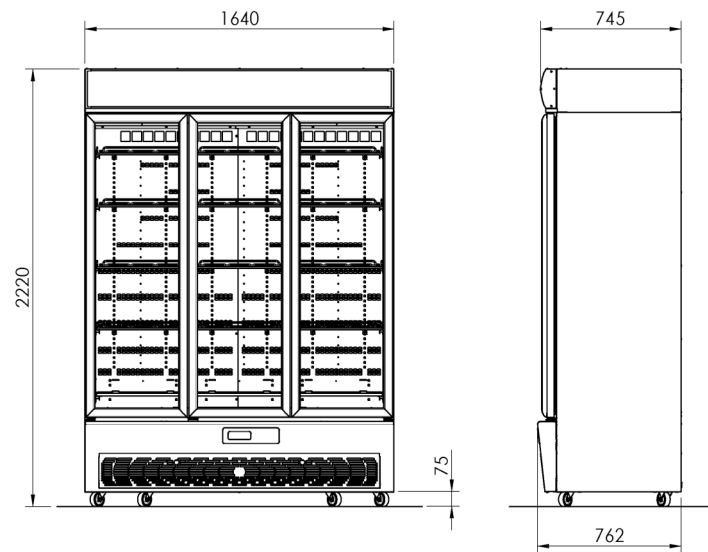
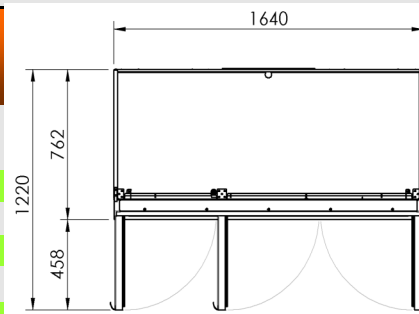

* Energy Consumption measured at 25°C. Cabinet Class 3M1 as per Australian Standard AS1731